

Notice of Meeting for The Baraboo-Wisconsin Dells Regional Airport Commission

Date and Time: **Thursday, December 16 2021 at 10:00AM**
Location: Baraboo City Hall, Room 205, 101 South Blvd., Baraboo, WI
Commissioners Noticed: Rob Nelson and Tom Diehl
Others Noticed: Casey Bradley, Kay Mackesey, Village of Lake Delton, Media, Bill Murphy, Joe Canepa, John Webb, Richard Cross, Bureau of Aeronautics (Joshua Holbrook), Kathleen Thurow

This meeting is open to the public. With the health concerns regarding COVID-19, the City requires anyone appearing in person to wear a mask and practice social distancing.

1. **CALL MEETING TO ORDER**
 - A. Roll Call of Membership
 - B. Note Compliance with the Open Meeting Law
 - C. Approval of minutes from November 5, 2021
 - D. Approval of the agenda

 2. **APPEARANCES/PRESENTATIONS** -None

 3. **PUBLIC COMMENT**

 4. **ACTION ITEMS**
 - A. Taxiway project
 - B. Easton Dreher Hangar Proposal
 - C. AWOS Replacement Discussion

 5. **INFORMATION ITEMS**
 - A. Report from Airport Manager, Casey Bradley

 - B. Report from FBO Bill Murphy

 - C. Airport Budget Reports and Balance Sheets

 - D. Fuel System Update

 - E. Next meeting date – Date to be determined

 6. **ADJOURNMENT**
-

Posted Agenda 12/15/2021 by D. Griggel

PLEASE TAKE NOTICE that any person who has a qualifying disability as defined by the Americans with Disabilities Act that requires the meeting or materials at the meeting to be in an accessible location or format, should contact the Baraboo City Clerk, 101 South Blvd, Baraboo, WI, or phone 608-355-2700, during regular business hours at least 48 hours before the meeting so that reasonable arrangements can be made to accommodate each request.

FOR INFORMATION ONLY AND NOT A NOTICE TO PUBLISH

1. Call Meeting to Order

Present: Rob Nelson (Baraboo), Tom Diehl (Village of Lake Delton).

Also Present: Casey Bradley (Airport Manager), Kathleen Thurow (Alderpersion), Ben Letendre, XXX

The owner representatives met at the Baraboo Municipal Building, 101 South Blvd, Room 205, Baraboo was open to the public for this meeting.

The meeting was called to order by Nelson at 10:00 AM and roll call was noted of those present by Nelson. Compliance of the Open Meeting Law was noted by Nelson.

Previous Minutes

Approval of the meeting minutes of April 30, 2021. A motion was made by Diehl, seconded by Nelson and approved unanimously.

Approve Agenda

Moved by Diehl to approve the agenda, seconded by Nelson and carried unanimously.

2. APPEARANCES/PRESENTATIONS - None**3. PUBLIC COMMENT – Ben Letendre****4. ACTION ITEMS**

- a. Solar Panels- Update from Diehl, Alliant will not locate on the SW corner of the airport, project will not be moving forward.
- b. Grants- Airport Manager Bradley provided an update on the status of the COVID funds received by the airport.
- c. Intergovernmental Agreement- Diehl voiced his frustrations regarding Baraboo's hesitancy to commit to projects based on a lack of funding available to Baraboo. Proposed an offer for the City Council to consider of having the Village of Lake Delton take over the Airport and the associated management of it.
- d. 2022 Budget- After discussion they decided the Master Plan needed to be moved into the capital expenditures. Motion by Nelson seconded by Diehl to approved the budget contingent on feedback from the Wisconsin Department of Transportation determination of how best to handle the status of the Taxiway, motion carried unanimously.
- e. Amendment of Fuel System Project Budget- Currently \$800,000 budgeted and amendment to \$803,000 is requested for BOA to hire a consultant to ensure wage rates and DBE requirements on the project. Local share is \$600. Motion by Diehl seconded by Nelson, motion carried unanimously.

INFORMATION ITEMS

- A. Report from Airport Manager, Casey Bradley-provided an update on fuel project.
- B. Report from FBO Bill Murphy-written report was reviewed.
- C. Fuel System- update was given
- D. Next meeting date – was not set pending feedback from DOT-BOA

Adjournment: motion by Diehl and seconded by Nelson and unanimously approved to adjourn at 11:30 AM.

ASSIGNMENT OF LEASE

FOR VALUE RECEIVED, the undersigned tenant hereby assigns to *MERRON BOK* all the tenant's right, title and interest in and to the lease between tenant and Baraboo-Wisconsin Dells Airport Commission as landlord dated the 1st day of October, 1969 with regard to the premises as follows:

Land located in the Southwest Quarter of the Northwest Quarter (SW $\frac{1}{4}$ NW $\frac{1}{4}$) of Section Fifteen (15), Township Twelve (12) North, of Range Six (6) East, Town of Delton, Sauk County, Wisconsin, described as follows: Commencing at a point on the centerline of paved runway of Baraboo-Wisconsin Dells Airport, which point is South 88 degrees 44 minutes 30 seconds East 1763.65 feet from the Southwest corner of the Southwest Quarter of the Northwest Quarter (SW $\frac{1}{4}$ NW $\frac{1}{4}$) of Section 15; thence North 10 degrees 21 minutes East 523.46 feet along the centerline of paved runway to centerline of taxiway; thence North 79 degrees 39 minutes West along centerline of taxiway and its extension 800 feet to the Westerly edge of the paved apron; thence South 10 degrees 21 minutes West, 471.0 feet along the Westerly edge of paved apron and extension thereof to the place of beginning for this description and running;

1. Thence, continuing South 10 degrees 21 minutes West 52.0 feet;
2. Thence, North 79 degrees 39 minutes West, 64.0 feet;
3. Thence, North 10 degrees 21 minutes East 52.0 feet;
4. Thence South 79 degrees 39 minutes East 64.0 feet to the place of beginning.

IN WITNESS WHEREOF, tenant has caused this instrument to be signed this 13TH day of July.

Vern Stevens

Tenant
VERN STEVENS

THIS LEASE AGREEMENT ("LEASE") is made and entered into by and between Baraboo-Wisconsin Dells Regional Airport Commission ("**LESSOR**"), created pursuant to §114.14(2)(a), Wis. Stat., for the purpose of operating and managing the Baraboo-Wisconsin Dells Regional Airport ("**AIRPORT**"), and **Easton Dreher** with a mailing address of **2433 Dells Parkway, Wisconsin Dells, WI 53965** (jointly referred to herein as the "**LESSEE**").

NOW, THEREFORE, for the mutual consideration stated herein, the Lessor and the Lessee agree as follows:

ARTICLE I LEASED PREMISES

- 1.1 The Lessor agrees to lease to the Lessee, and the Lessee agrees to lease from the Lessor, the following described portion of the Airport ("**LEASED PREMISES**"):

LOT # 4- A parcel of land approximately **52.0'** feet wide by **64.0'** feet long and containing approximately **3328** square feet, which is more specifically shown on Exhibit 1 which is attached to and made a part of this Lease.

ARTICLE II PURPOSE

- 2.1 The Leased Premises is to be used by the Lessee for the purpose of the Lessee constructing of a ("**HANGAR**") that will be used by the Lessee for the inside storage of aircraft owned by Lessee and the storage of related materials and supplies, and for no other purpose unless approved in writing by the Lessor hangar.

ARTICLE III TERM

- 3.1 Lease Term. This Lease shall be in full force and effect from the date of full execution ("**EFFECTIVE DATE**") by the Parties and will then run for a twenty-five year period, from July _____, 2021 ("**CALENDAR DATE**") until July _____, 2046 ("**EXPIRATION DATE**"), unless terminated sooner as permitted by this Lease.
- 3.2. Renewal. Lessee shall have the option to renew this Lease for consecutive five- (5-) year periods subject to the terms and conditions hereof, including the provisions governing the renegotiations of rental fees ("**RENEWAL TERM**").
- 3.2.1 Notice to exercise a **Renewal Term** must be submitted by the Lessee to the Lessor at least six (6) months prior to the Expiration Date, and at least six (6) months prior to the expiration date of a renewal term, as applicable.
- 3.2.2 Upon receipt of a notice to exercise a **Renewal Term**, the Lessor shall prepare an addendum to this Lease which shall reflect the Lessor's current terms and conditions for Hangar Land Leases. Any modifications to the lease terms and conditions shall commence with the start of each **Renewal Term**.
- 3.2.3 The Lessor may deny the Lessee's request to exercise a **Renewal Term** if the Lessee is in

Lot 3 and 4 Hangar Project

4130 Whispering Pines
Baraboo, WI 53965
920-979-4401
Easton@ExploreVI.com

Airport Commission:

I am proposing to build a new hangar in place of the T-Hangars on Lot 3 and 4 at the Baraboo Airport. If this conceptual plan is approved I would like to proceed by removing both T-Hangars and constructing the plan attached.

The building description as follows:

- 35' x 108' single slope structure
- High eave at 24' and low at 14'
- Designed with an 3.4/12 roof pitch
- Clear span (steel)
- -Fully Insulated R19
- Designed with 26 gauge PBR roof and wall panels
- Front side wall designed with (2) 42 x 12, (1) 9x9, and (1) 4x4 framed openings
 - Both hangar doors will have a hydraulic single pane opening door
 - The garage door will be a 9x9 roll up door

Four Pages attached:

1. A map showing the real location with an outline where the building will be placed.
2. A 3D rendering of the building, description, lot lines, and setbacks.
3. Lot 3 lease agreement lot size
4. Lot 4 lease agreement lot size

Please let me know if you have any questions. I look forward to working with you on this project.

Thank you for your time.

Easton Dreher

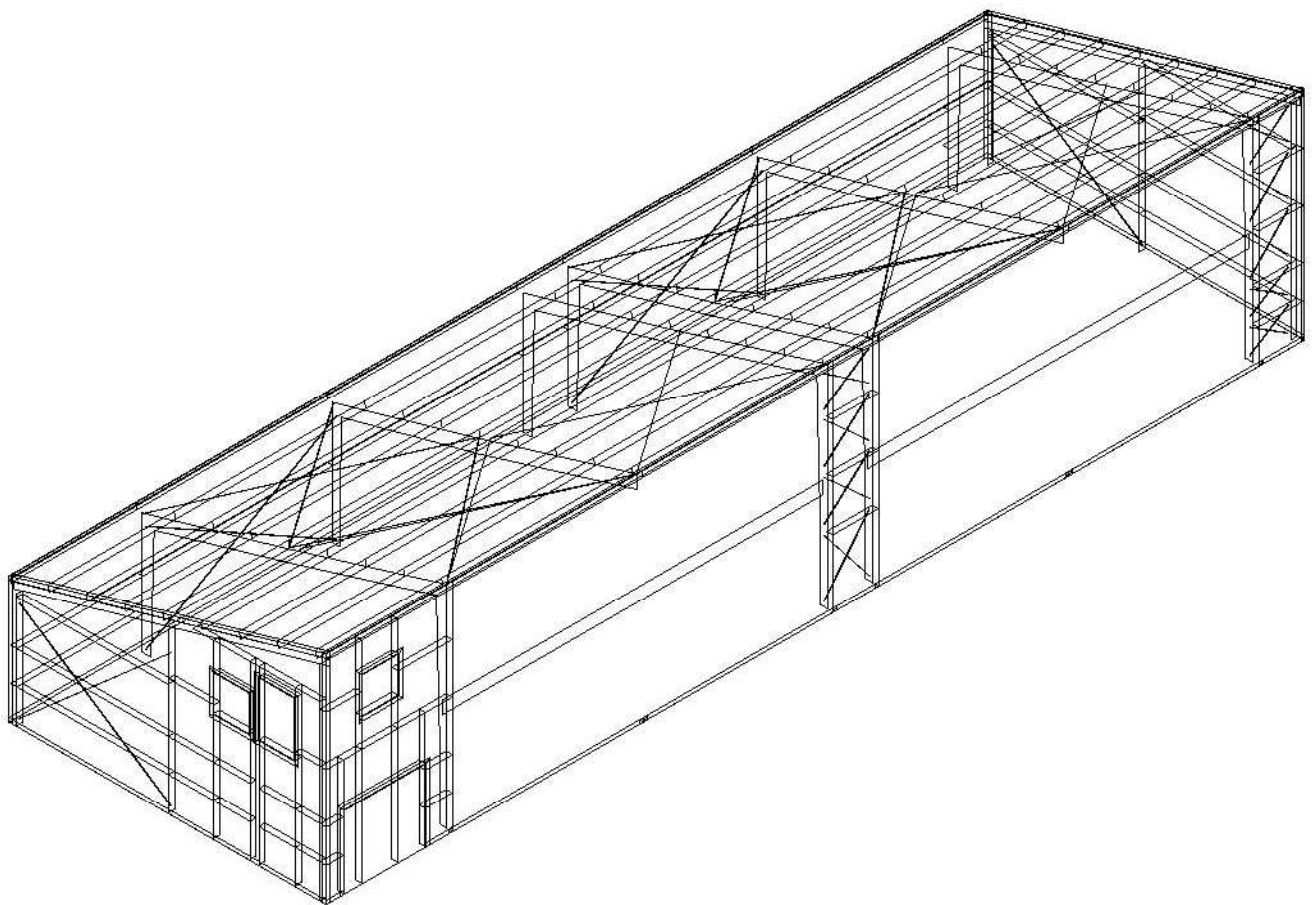



Map data ©2021 , Map data ©2021 20 ft

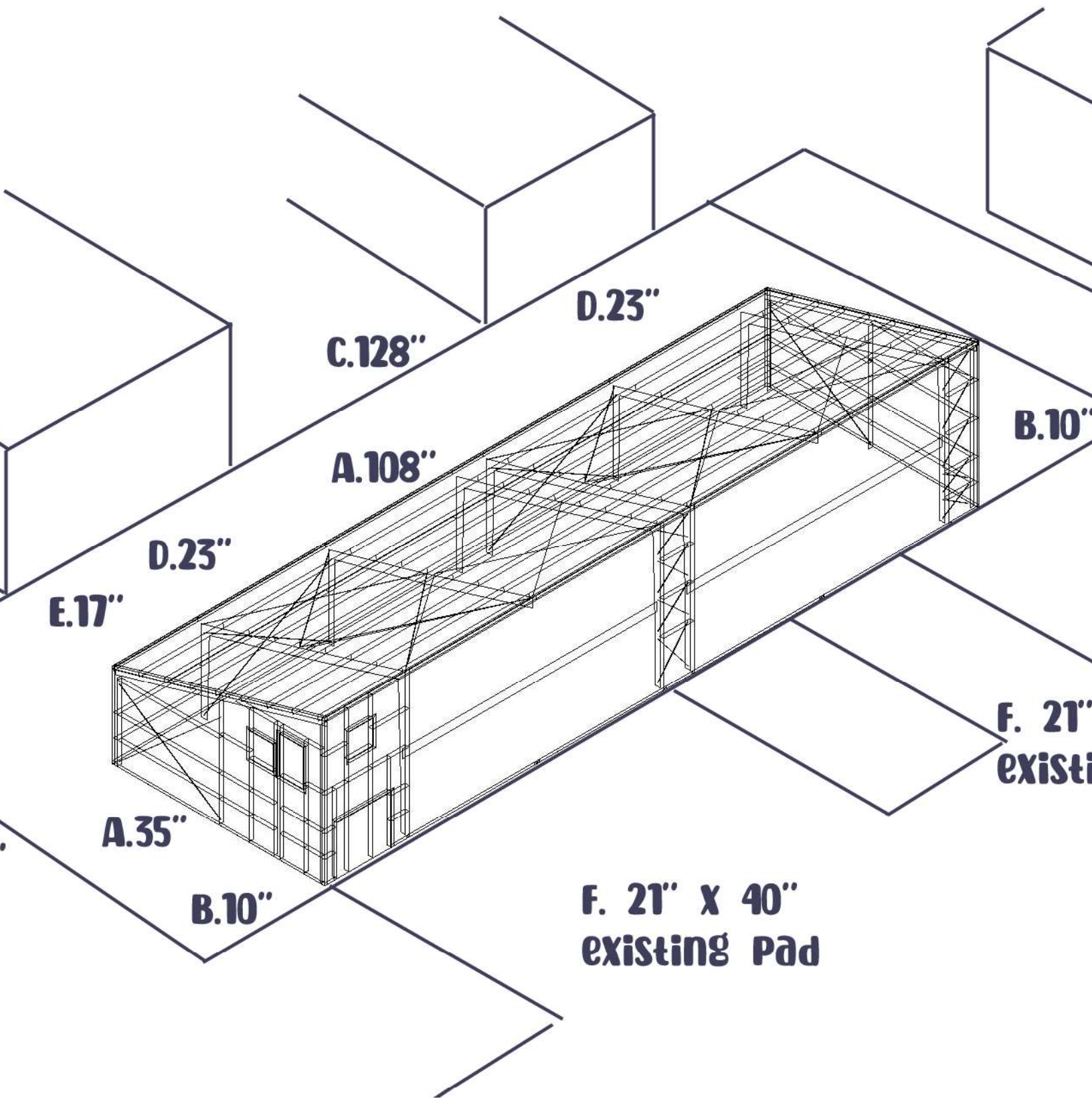

From: Holbrook, Joshua P - DOT <Joshua.Holbrook@dot.wi.gov>
Sent: Tuesday, November 30, 2021 3:04 PM
To: Bradley, Casey <cbradley@cityofbaraboo.com>
Subject: RE: DLL AWOS Replacement

Casey,

The Master Plan (MP) would not be affected as we are going to fund that out apportionment money (essentially State discretionary funds). The AWOS would most likely spend your 2019 entitlement. So, unless the terminal was going to start ASAP, which it isn't, it shouldn't really affect it.

Josh

From: Bradley, Casey <cbradley@cityofbaraboo.com>
Sent: Tuesday, November 30, 2021 1:40 PM
To: Holbrook, Joshua P - DOT <Joshua.Holbrook@dot.wi.gov>
Subject: FW: DLL AWOS Replacement

**CAUTION: This email originated from outside the organization.
Do not click links or open attachments unless you recognize the sender and know the content is safe.**

Josh,

If we were to replace the AWOS how would that impact our ability to proceed with the Master Plan and the Terminal from a funding standpoint?

Casey Bradley
City Administrator
101 South Blvd.
Baraboo, WI 53913
Office 608-355-2715
Cell 608-393-1688

From: bill@baraboodellsairport.com <bill@baraboodellsairport.com>
Sent: Monday, November 29, 2021 11:12 AM
To: Bradley, Casey <cbradley@cityofbaraboo.com>
Subject: RE: DLL AWOS Replacement

Hi Casey,

I can't seem to get a straight answer on when the AWOS was replaced so I'd say if there is funding for this and they cover 100% of repairs we should definitely do it. That system is vital to our operation and the safety of our users.

Thank you,

Bill Murphy

Baraboo-Dells Flight Center, Inc.

S3440 County Road BD
Baraboo, WI 53913
Office: 608-356-2270
Cell:608-393-3552

From: Bradley, Casey <cbradley@cityofbaraboo.com>
Sent: Thursday, November 11, 2021 11:29 AM
To: Bill Murphy <bill@baraboodellsairport.com>
Subject: FW: DLL AWOS Replacement

Thoughts?

Casey Bradley
City Administrator
101 South Blvd.
Baraboo, WI 53913
Office 608-355-2715
Cell 608-393-1688

From: Graczykowski, Mark - DOT <Mark.Graczykowski@dot.wi.gov>
Sent: Thursday, November 11, 2021 8:53 AM
To: Bradley, Casey <cbradley@cityofbaraboo.com>
Cc: Cothren, Joshua W - DOT <joshua.cothren@dot.wi.gov>; Holbrook, Joshua P - DOT <Joshua.Holbrook@dot.wi.gov>
Subject: DLL AWOS Replacement

Good Morning Casey,

We are in the process of developing a statewide bid for AWOS replacements and the DLL AWOS is from 1994 and exceeded its useful life. In addition, the statewide maintenance program is good for 15 years after installation and therefore if a major repair was needed right now it would cost DLL 100%. If we replace the AWOS, the 15-year program starts over and our goal moving forward is to plan for the replacements in your CIP to keep DLL in the maintenance program where WBOA picks up 100% of the costs.

The replacement is AIP eligible, and we would be looking to use Entitlements to complete the project. The estimated cost for a full replacement is currently \$180,000, so we'd use just over a year's worth of funding.

If you are interested in being in the 2022 program (looking to bid 4 or 5 AWOS together statewide), we would need to get a petition for this item and I know you recently just completed one. Could be timely to also include the rehab of Taxiway A.

Any questions please let us know. If you have AWOS program specific questions, I've cc'd Josh Cothren who is our AWOS PM in the Tech Services section.

Thanks,

Mark

Mark Graczykowski, P.E.
Airport Program Engineer
WisDOT - Bureau of Aeronautics
Phone: 608-266-0902
Email: mark.graczykowski@dot.wi.gov



Upcoming Leave: 11/5, 11/16-11/23, 11/25, 12/2-12/6
Upcoming Work Travel: None currently

City of Baraboo
Airport Fund 630
Balance Sheets
November 30, 2021 and December 31, 2020

Assets:	November 30, 2021	December 31, 2020
<i>Current Assets:</i>		
Cash	\$ 58,369.53	\$ 21,025.93
Accounts Receivable	408.98	757.09
Due from State	-	59,285.44
Prepaid Expenses	-	11,040.94
Advance to Airport Capital Fd	-	-
<i>Total Current Assets</i>	58,778.51	92,109.40
Total Assets	\$ 58,778.51	\$ 92,109.40
Liabilities and Fund Equity:		
<i>Liabilities:</i>		
Accounts Payable	\$ -	\$ 1,639.78
Deferred Revenue	-	759.68
Def Revenue-Expenditure Grant	-	59,285.44
Advance from General	-	-
<i>Total Liabilities</i>	-	61,684.90
<i>Fund Equity:</i>		
Fund Balance	19,383.56	(3,846.46)
Non-Spendable Prepaid Expenses	11,040.94	11,040.94
Net Revenues/(Expenditures)	28,354.01	23,230.02
<i>Total Fund Equity</i>	58,778.51	30,424.50
Total Liabilities and Fund Equity	\$ 58,778.51	\$ 92,109.40

City of Baraboo
Airport Fund 630
Income Statement with Comparison to Budget
For The eleven Months Ending November 30, 2021

Revenues:	Current Month	Year to Date	Budget	Percentage of Budget
Federal Transportation Grant	\$ -	\$ -	\$ 190,000.00	-
Federal Trans Grant - CARES	\$ -	\$ 69,000.00	\$ 78,000.00	88.46
Local Transportation Aid	-	-	-	-
Gas Sales	2,491.27	10,965.45	6,500.00	168.70
Landing Fee	-	-	4,665.00	-
Appropriations_ County	-	8,200.00	8,200.00	100.00
Appropriations- City	-	40,000.00	40,000.00	100.00
Appropriations-Lake Delton	-	40,000.00	40,000.00	100.00
Interest on Investments	18.04	225.52	140.00	161.09
Rents and Leases	1,365.34	18,151.08	18,000.00	100.84
Ag Land Rental	-	9,500.00	9,500.00	100.00
Hangar Lot Lease	-	27,422.67	27,244.00	100.66
Hangar Keeper Fee	-	-	-	-
Hangar rental	-	-	-	-
Sale of Assets	-	-	-	-
Insurance Recoveries	-	-	-	-
Refund of Prior Years Expense	-	-	-	-
Miscellaneous Income	622.53	688.71	-	-
Proceeds from Notes	-	-	-	-
Fund Balance Applied	-	-	-	-
Total Revenues	\$ 4,497.18	\$ 224,153.43	\$ 422,249.00	53.09

Expenditures:

Airport - Airport - Airport

Wages	\$ 251.34	\$ 7,730.72	\$ 9,600.00	80.53
Social Security	59.26	768.31	713.00	107.76
Retirement	67.53	865.40	780.00	110.95
Health Insurance	213.54	2,638.50	1,624.00	162.47
Life Insurance	-	-	5.00	-
Income Continuation	-	-	-	-
Contracted Services	3,535.00	38,885.00	42,420.00	91.67
Publishing	-	24.99	40.00	62.48
Professional Services	577.68	11,463.70	212,200.00	5.40
Telephone	63.46	636.22	700.00	90.89
Electricity	518.23	5,111.08	7,000.00	73.02
Heat	19.73	693.49	2,000.00	34.67
Repair & Maint Serv-Equipment	-	11,450.08	17,968.00	63.72
Fuel Station Maintenance	-	4,591.81	3,000.00	153.06
Repair & Maint Serv-Buildings	70.00	675.98	1,200.00	56.33
Special Services	-	2,000.00	2,000.00	100.00
DOT Maintenance Agreement	-	-	-	-
Repair & Maint Serv-Facilities	-	2,407.76	12,500.00	19.26

City of Baraboo
Airport Fund 630
Income Statement with Comparison to Budget (Continued)
For The eleven Months Ending November 30, 2021

Expenditures (Continued):	Current Month	Year to Date	Budget	Percentage of Budget
<i>Airport - Airport - Airport (Continued)</i>				
Snow Removal & Mowing	-	-	-	-
Lighting Repairs	-	861.25	400.00	215.31
Runway & Taxi Repairs	600.00	10,600.00	10,000.00	106.00
Road Repair	-	-	-	-
Other Contracted Services	50.00	50.00	-	-
Office Supplies	-	65.89	50.00	131.78
Publications. Training. Dues	-	-	240.00	-
Travel	-	-	60.00	-
Operating Supplies	-	6,992.53	7,500.00	93.23
Gas. Diesel. Oil. Grease	(102.43)	3,716.97	4,800.00	77.44
Repair & Maint Materials	-	892.75	750.00	119.03
Repair & Maint - Buildings	-	-	499.00	-
Other Supplies & Expense	-	-	-	-
Small Equipment Purchase	-	799.99	500.00	160.00
Insurance	-	12,877.00	9,700.00	132.75
Rents and Leases	-	-	-	-
Extraordinary Expense	-	-	-	-
Equipment Purchases	-	-	5,000.00	-
Land or Land Improvements	-	-	-	-
Building Improvements	-	-	-	-
Facilities Improvements	-	-	-	-
Equipment Replacement	-	-	-	-
Cost Allocation	-	-	-	-
Cost Reallocation	69,000.00	69,000.00	69,000.00	100.00
<i>Total Airport - Airport - Airport</i>	\$ 74,923.34	\$ 195,799.42	\$ 422,249.00	46.37
Total Expenditures	\$ 74,923.34	\$ 195,799.42	\$ 422,249.00	46.37
Net Revenues/(Expenditures)	\$ (70,426.16)	\$ 28,354.01	\$ -	

City of Baraboo
Airport Capital Imprvmnt Fund Fund 632
Balance Sheets
November 30, 2021 and December 31, 2020

Assets:	<u>November 30, 2021</u>	<u>December 31, 2020</u>
<i>Current Assets:</i>		
Cash	\$ 169,051.69	\$ 114,859.37
Due from State	13,568.02	13,568.02
Due from Other Cities. Village	-	-
<i>Total Current Assets</i>	<u>182,619.71</u>	<u>128,427.39</u>
Total Assets	<u><u>\$ 182,619.71</u></u>	<u><u>\$ 128,427.39</u></u>
 Liabilities and Fund Equity:		
<i>Liabilities:</i>		
Accounts Payable	\$ -	\$ 21,472.61
Due to State	-	-
Advance from Airport Operating	-	-
<i>Total Liabilities</i>	<u>-</u>	<u>21,472.61</u>
 <i>Fund Equity:</i>		
Fund Balance	106,954.78	116,124.27
Net Revenues/(Expenditures)	75,664.93	(9,169.49)
<i>Total Fund Equity</i>	<u>182,619.71</u>	<u>106,954.78</u>
Total Liabilities and Fund Equity	<u><u>\$ 182,619.71</u></u>	<u><u>\$ 128,427.39</u></u>

City of Baraboo
Airport Capital Imprvmnt Fund Fund 632
Income Statement with Comparison to Budget
For The eleven Months Ending November 30, 2021

Revenues:	Current Month	Year to Date	Budget	Percentage of Budget
Federal Transportation Grant	\$ -	\$ -	\$ 692,210.00	-
Local Transportation Aid	-	-	69,000.00	-
Appropriations	-	-	-	-
Appropriations- City	-	-	-	-
Appropriations-Lake Delton	-	-	-	-
Interest on Investments	14.17	216.11	-	-
Sale of Assets	-	-	-	-
Insurance Recoveries	-	-	-	-
Refund of Prior Years Expense	-	-	-	-
Transfer from Airport Operatng	69,000.00	69,000.00	-	-
Fund Balance Applied	-	-	107,790.00	-
Total Revenues	\$ 69,014.17	\$ 69,216.11	\$ 869,000.00	7.97
Expenditures:				
<i>Airport Capital Imprvmnt Fund - Interest on Notes</i>				
Interest	-	-	-	-
Total Airport Capital Imprvmnt Fund	\$ -	\$ -	\$ -	-
<i>Airport Capital Imprvmnt Fund - Capital Losses</i>				
Other Supplies & Expense	-	-	-	-
Total Airport Capital Imprvmnt Fund	\$ -	\$ -	\$ -	-
<i>Airport Capital Imprvmnt Fund - Airport - Airport</i>				
Wages	-	-	-	-
Social Security	-	-	-	-
Retirement	-	-	-	-
Health Insurance	-	-	-	-
Equipment Purchases	-	-	-	-
Land or Land Improvements	-	-	-	-
Building Improvements	-	-	-	-
Facilities Improvements	-	(6,448.82)	869,000.00	(0.74)
Facilities Improvements-Contra	-	-	-	-
Total Airport Capital Imprvmnt Fund	\$ -	\$ (6,448.82)	\$ 869,000.00	(0.74)
Total Expenditures	\$ -	\$ (6,448.82)	\$ 869,000.00	(0.74)
Net Revenues/(Expenditures)	\$ 69,014.17	\$ 75,664.93	\$ -	